

Installation Manual

PowerRouter Solar Battery – self-use



Illustrations

Page 1

EN

Installation Manual

Original instructions

Page 11

1

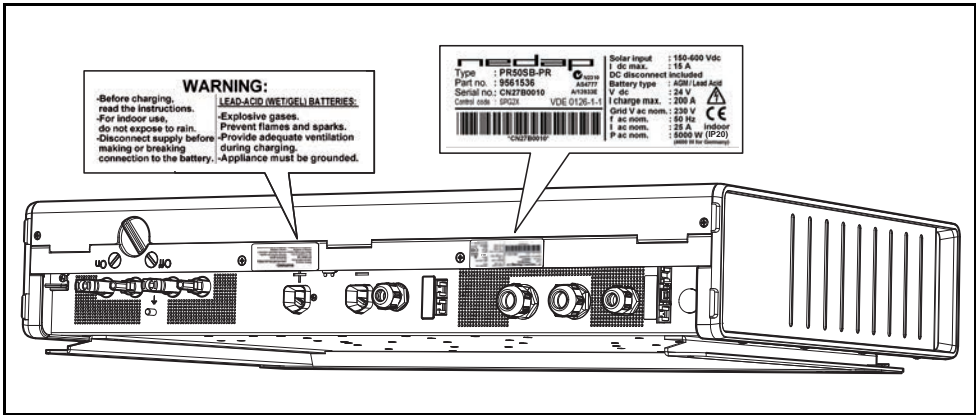

2

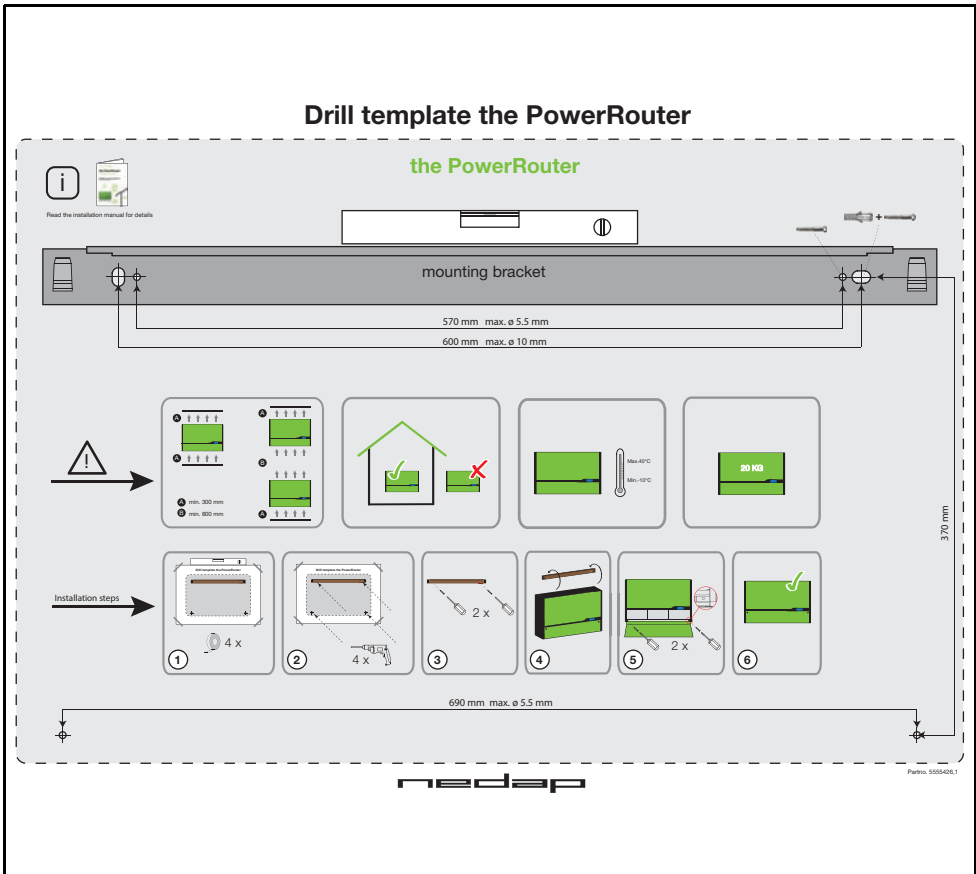

3

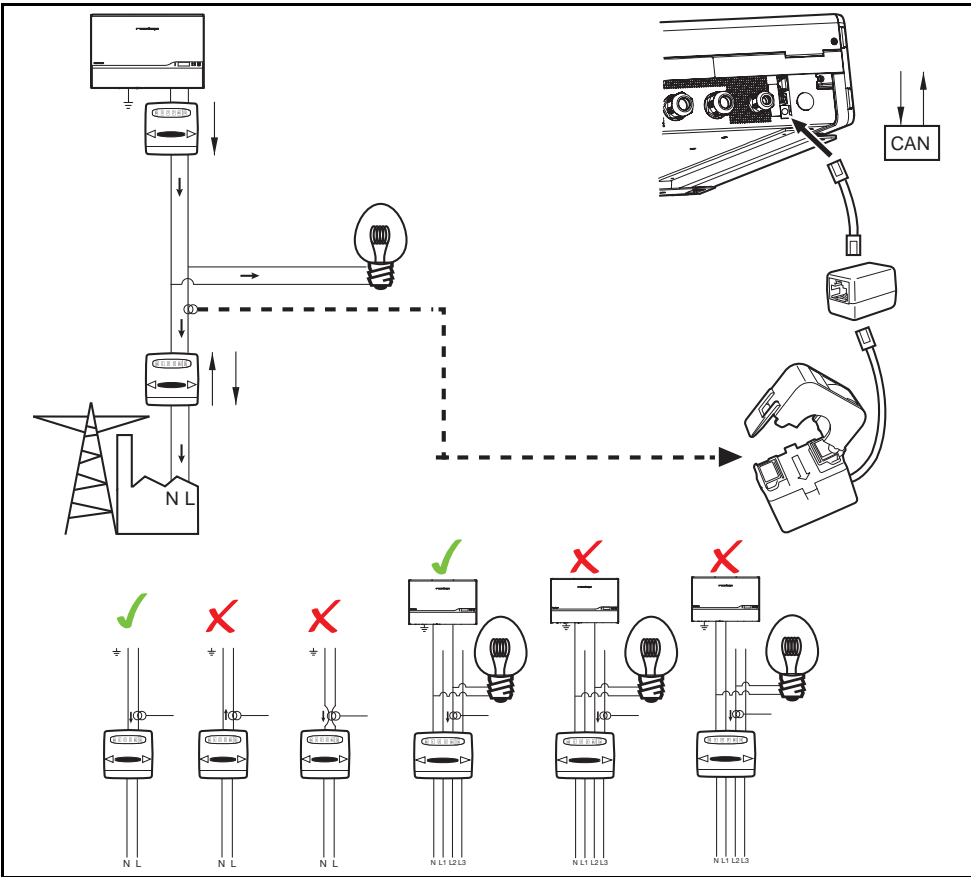

4

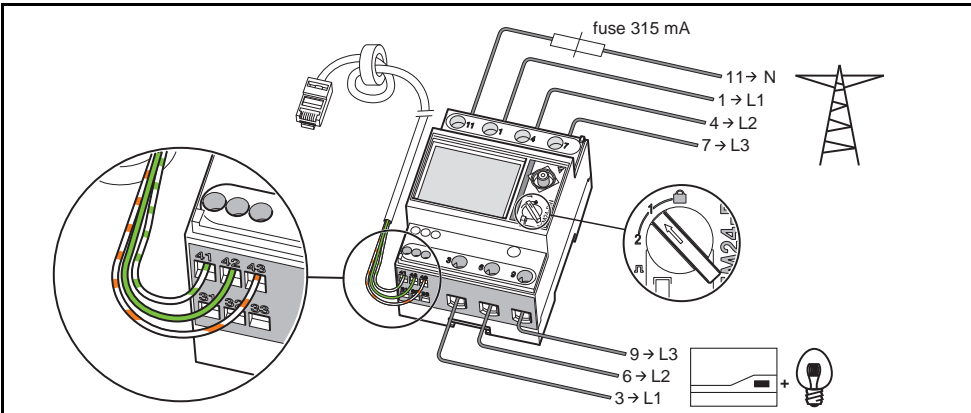

5

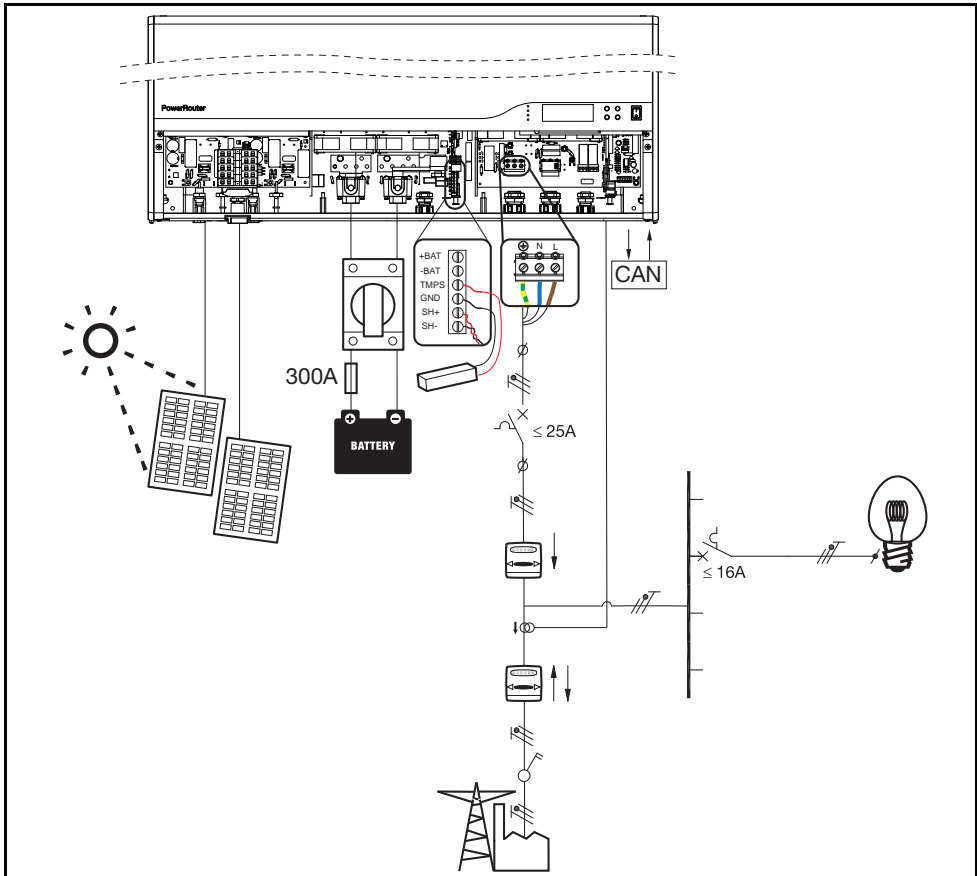

6

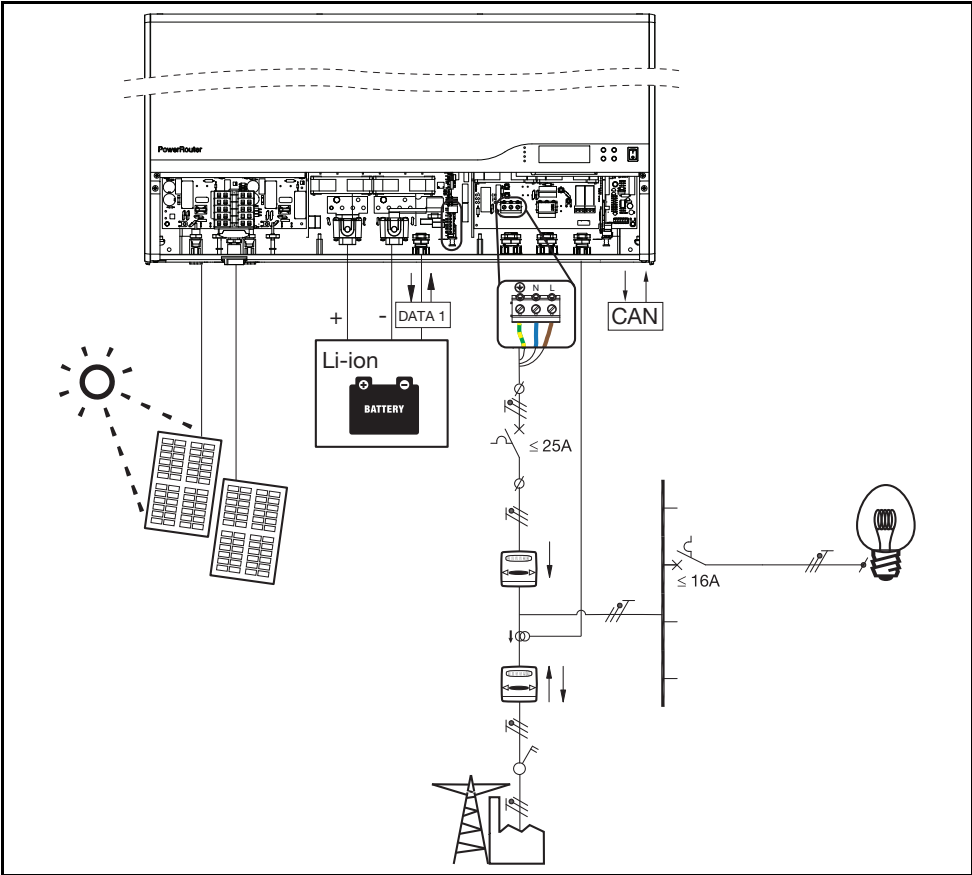

7

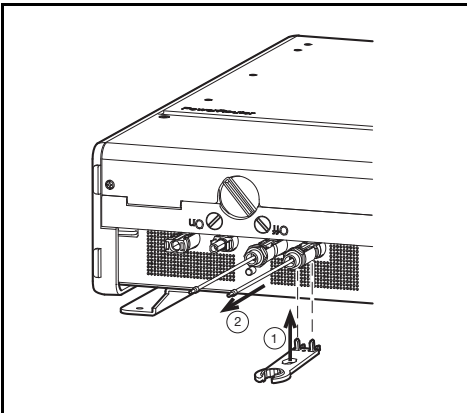

8

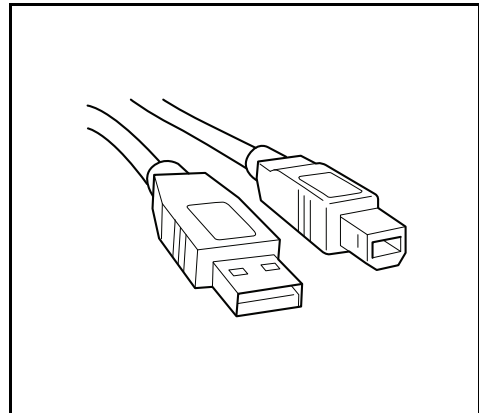

9

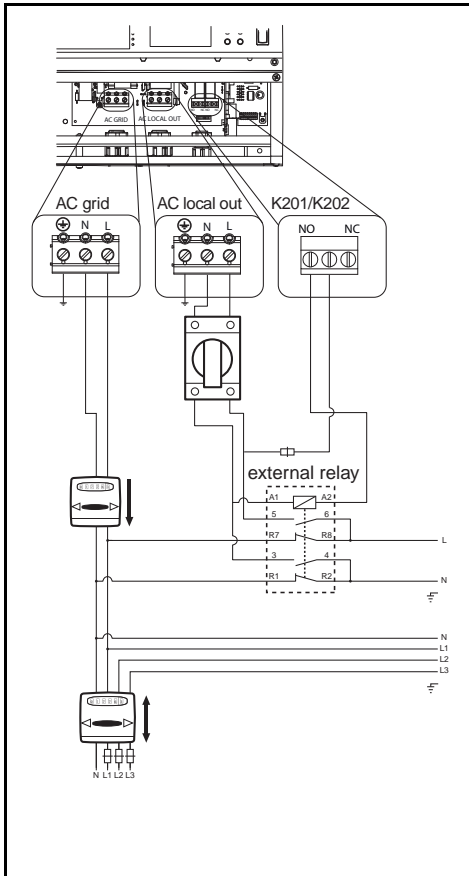

10

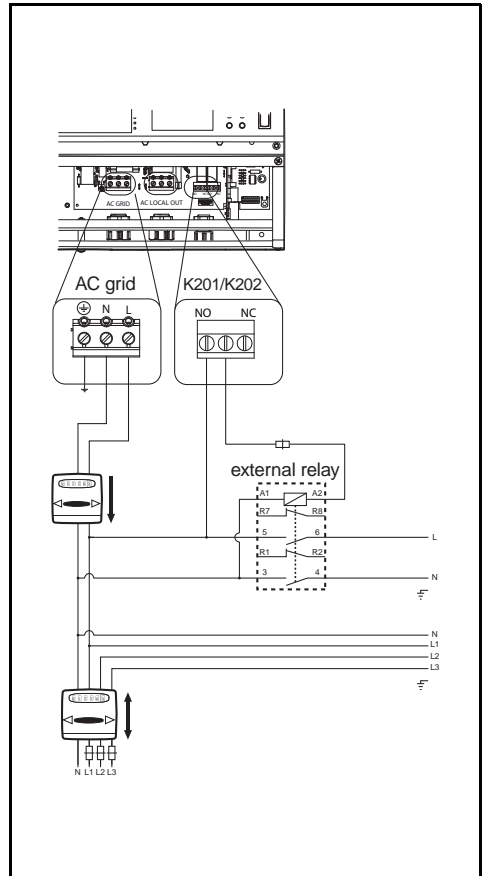

11

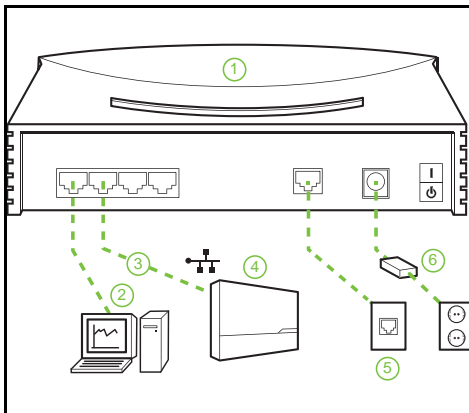

12

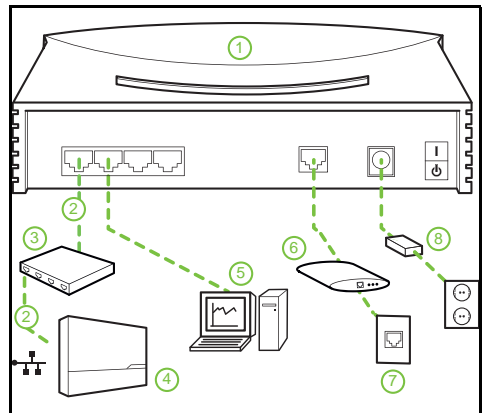

13

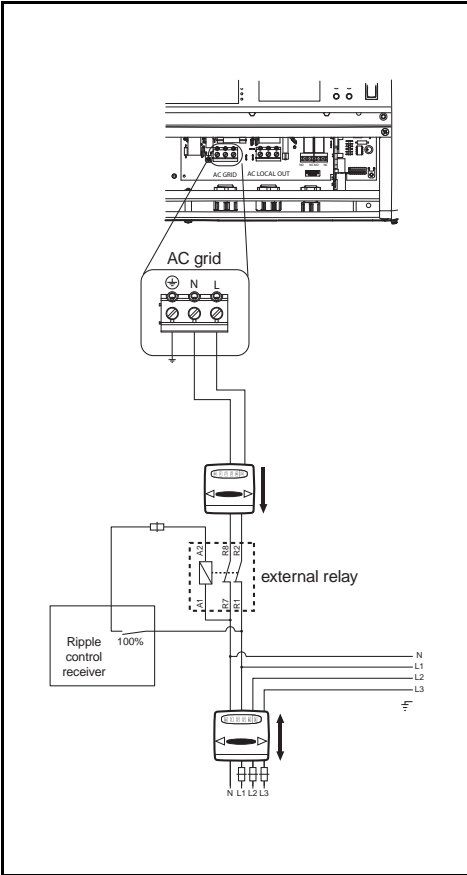

14

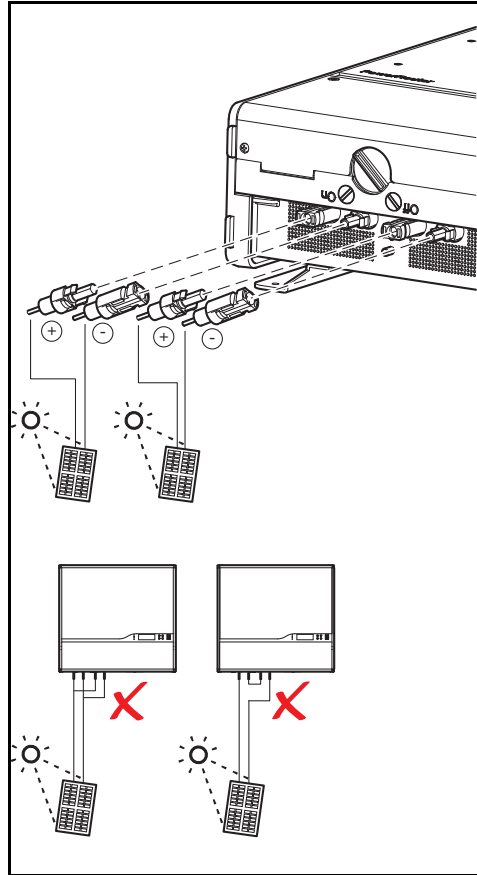

15

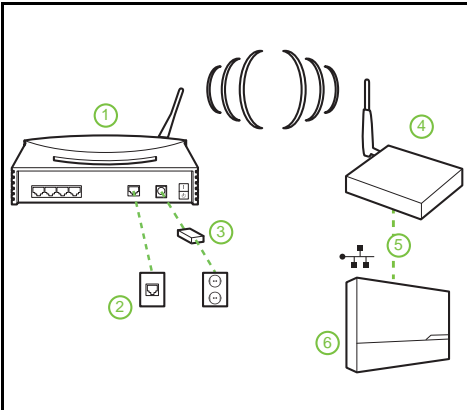

16

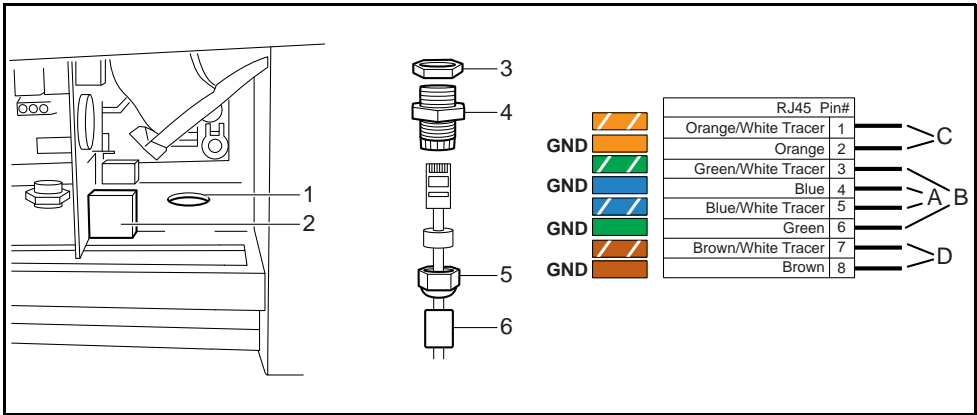

17

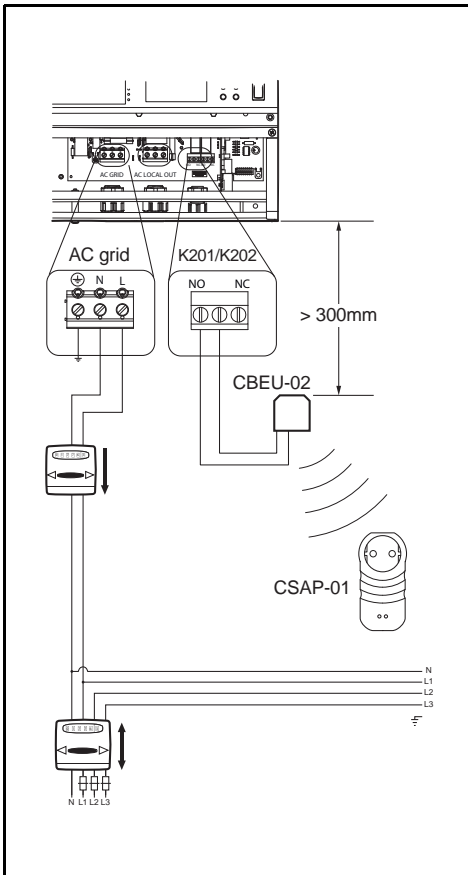

18

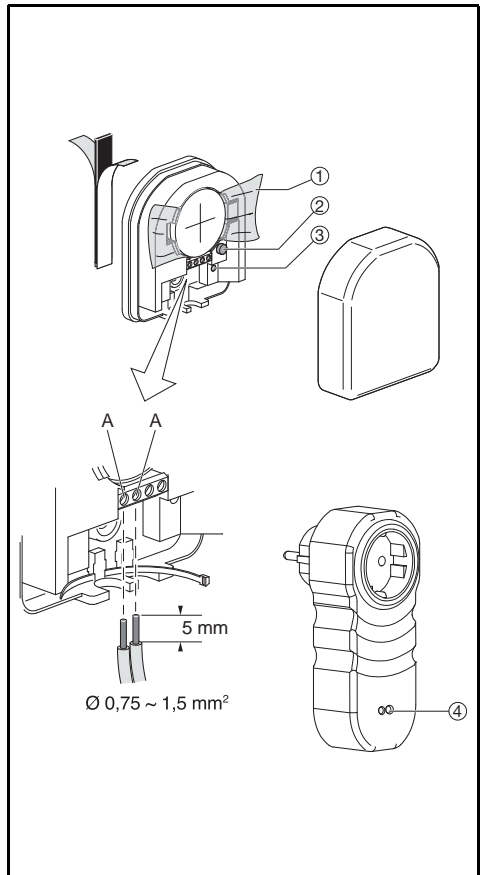

19

20

21

22

23

My data | **My PowerRouters** | My finances | My theme | My widgets | Twitter

PR50SB-BS Self-use | PR50S | PR37S | **New PowerRouter**

General | Solar inputs | Location

Description: PR50SB-BS Self-use
 Serial no.: 9561773B101DEMO1
 Type label: PR50SB-BS/S240
 Version: 3.3.3
 Installation date: 18-01-2012
 Battery: 225 Ah

New PowerRouter | Remove PowerRouter | Save my settings

24

My data | **My PowerRouters** | My finances | My theme | My widgets | Twitter

PR50SB-BS Self-use | PR50S | PR37S | **New PowerRouter**

Enter the following data about your PowerRouter and click on register

Part no.
 Serial no.
 Control code

On the back of the PowerRouter you will find a corresponding sticker like depicted here. Take the serial & part no. and the control code from it and enter this data into their corresponding fields.

nedap
 Type : PR50S/EU
 Part no. : 9560698
 Serial no. : A722B0002
 Control code: 7X744

Solar input : 150-600 Vdc
 I dc max. : 15 A
 DC disconnect included

Grid V ac nom.: 230 V
 f ac nom. : 50 Hz
 I ac nom. : 25 A
 P ac nom. : 5000 W
 IP21
 (900 W for Germany)

Cancel registration | Register PowerRouter

Contents

Contents	11
1 Introduction	14
1.1 <i>Applicability</i>	14
1.2 <i>Symbols used in the documentation</i>	14
1.3 <i>Warranty</i>	14
2 Safety	17
2.1 <i>General safety</i>	17
2.2 <i>PowerRouter</i>	17
2.3 <i>Local grid</i>	17
2.4 <i>Public grid</i>	17
2.5 <i>Solar panels</i>	18
2.6 <i>Batteries</i>	18
3 General description	19
3.1 <i>The PowerRouter - intended use</i>	19
3.1.1 <i>Internet connection</i>	19
3.1.2 <i>PowerRouter software installation tool</i>	19
3.2 <i>1-phase sensor (accessory PRA1SENSE)</i>	19
3.3 <i>3-phase sensor (accessory PRA3SENSE)</i>	20
3.4 <i>External relay (accessory PRA1RLY)</i>	20
3.5 <i>Wireless Energy Management Kit (accessory PRA1WEMK)</i>	20
3.6 <i>Batteries</i>	20
3.7 <i>Battery temperature sensor</i>	21
4 Installation	22
4.1 <i>Check the contents of the PowerRouter box</i>	22
4.2 <i>Determine the mounting location</i>	22
4.3 <i>Mount the PowerRouter</i>	23
4.4 <i>Connect the AC grid</i>	23
4.5 <i>Connect the solar panels</i>	24
4.6 <i>Connect the 24V lead-acid batteries</i>	25
4.7 <i>Connect the 48V Li-ion batteries</i>	25
4.8 <i>Connect a self-use sensor</i>	26
4.8.1 <i>Connect the 1-phase sensor (accessory)</i>	26
4.8.2 <i>Connect the 3-phase sensor (accessory)</i>	26
4.9 <i>Connect the external relay (accessory)</i>	27
4.9.1 <i>Connect the external relay for energy management</i>	27

EN

- 4.9.2 Connect the external relay to isolate the PowerRouter from the public grid 27
- 4.9.3 Connect the external relay for a backup power supply 27
- 4.10 Install the PRA1WEMK 28**
- 4.11 Connect the additional cable (Italy) 29**
- 4.12 Switch on the system 29**
- 4.13 Initialise the PowerRouter 30**
 - 4.13.1 Installation wizard (on the display) 30
 - 4.13.2 Software installation tool (for advanced settings) 30
 - 4.13.3 Run the self test (Italy) 31
- 4.14 Connect the PowerRouter to the internet 32**
 - 4.14.1 Connect to an internet router 32
 - 4.14.2 Connect via a switch to an internet router 32
 - 4.14.3 Connect to a wireless access point 33
 - 4.14.4 Register the PowerRouter on www.myPowerRouter.com 33
 - 4.14.5 Register additional PowerRouters on one login 33
- 5 Software installation tool 35**
 - 5.1 Introduction 35**
 - 5.2 Display settings 35**
 - 5.2.1 Backlight 35
 - 5.2.2 Display 35
 - 5.2.3 Language 35
 - 5.3 PowerRouter settings 36**
 - 5.3.1 Scenario 36
 - 5.3.2 Alarm 1 / Alarm 2 36
 - 5.3.3 Standby 37
 - 5.3.4 Standby timer 37
 - 5.4 Grid 37**
 - 5.4.1 Country 37
 - 5.4.2 EEG 2012 37
 - 5.4.3 VDE 4105 37
 - 5.4.4 Dynamic feed-in limiter 37
 - 5.5 Battery pack 38**
 - 5.5.1 Battery charging 38
 - 5.5.2 Maintenance charge 38
 - 5.5.3 Self-use battery settings 38
 - 5.5.4 Wintermode 38
- 6 Operation 39**
 - 6.1 Display menu 39**
- 7 Troubleshoot 40**
 - 7.1 Troubleshooting 40**
 - 7.2 Check the LED status 40**
 - 7.3 Check the error messages 41**
 - 7.4 Error explanation 41**
 - 7.4.1 Hard error 41
 - 7.4.2 Soft error 41

7.4.3	Error code	41
7.5	Errors	42
7.6	Procedures	46
7.6.1	Restart the PowerRouter	46
7.6.2	Check the PowerRouter airflow	46
7.6.3	Check the internet connection	46
7.6.4	Look up the firmware versions and id number	46
7.6.5	Reset the PowerRouter	46
8	De-installation	47
8.1	De-install	47
8.2	Disposal	48
9	Technical specifications	49
9.1	Technical specifications of the PowerRouter SB models	49
9.2	Technical specifications of the PowerRouter SBi models	50

1 Introduction

1.1 Applicability

This installation manual is intended for qualified installation personnel. It describes how you can safely install, connect and start the following PowerRouter types:

- PR50SB-BS
- PR37SB-BS
- PR30SB-BS
- PR50Sbi-BS
- PR37Sbi-BS

1.2 Symbols used in the documentation



DANGER

This symbol indicates a hazardous situation which, if not avoided, could result in death or serious injury.



WARNING

This symbol indicates a situation which, if the instructions are not followed, could result in injury and damage to the equipment.



CAUTION

This symbol indicates a situation which, if the instructions are not followed, could result in damage to the equipment.



This symbol indicates additional information to ensure optimal operation of the system.

1.3 Warranty

PowerRouter factory warranty conditions

Our quality control program ensures that each PowerRouter product is manufactured to exact specifications and is thoroughly tested before leaving the factory.

5 year warranty

The Nedap factory warranty period is 5 years from the purchase date of the PowerRouter system. The warranty conditions are based on EU Directive 99/44/EC, without prejudice to any legal rights.

Extended warranty

For all PowerRouter systems you can acquire a 5-year extension to the PowerRouter factory warranty, for a total of 10 years of warranty coverage. The extended warranty can only be purchased within 6 months of the PowerRouter delivery date.

Warranty conditions

If a PowerRouter becomes defective during its warranty period, one of the following services will be performed at no charge for materials, but exclusive of labour costs, at the discretion of the PowerRouter Helpdesk:

- Repair at Nedap N.V.
- Repair on site
- Exchange for a replacement unit (of equivalent value according to model and age)

Exclusion of liability

Warranty claims and liability for direct or indirect damage are excluded if arising from:

- Transport and storage damage
- Incorrect installation and/or commissioning
- Modifications, changes or attempted repairs by untrained and unauthorised personnel
- Incorrect use or inappropriate operation
- Insufficient ventilation of the device
- Failure to observe the applicable safety regulations
- Force majeure (e.g. lightning, overvoltage, storm, fire)
- Cosmetic shortcomings which do not influence the functioning of the unit
- Damage due to moisture and/or other environmental conditions



The installer/dealer who installed the PowerRouter must report the defective PowerRouter system to the PowerRouter Helpdesk. Nedap reserves the right to replace the unit with one having equal or better specifications, at Nedap's judgement.

Information for Australian purchasers - Consumer statutory rights

In Australia, this warranty is given by, and all Australian warranty claims should be directed to:

Nedap Energy Systems Australia
4B/4602 Mitchell Highway
Lucknow NSW 2795
Telephone: 1300 939 430
Email: support-au@PowerRouter.com

The benefits to the consumer given by this factory warranty are in addition to other rights and remedies of the consumer that are stipulated by law, and which are not affected by this factory warranty.

Our products come with guarantees that cannot be excluded under the Australian Consumer Law. You are entitled to a replacement or refund for a major failure and for compensation for any other reasonable foreseeable loss or damage. You are also entitled to have the goods repaired or replaced if the goods fail to be of acceptable quality and the failure does not amount to a major failure.

Disclaimer

All rights to the content of this manual are owned by N.V. Nederlandsche Apparatenfabriek 'Nedap' (hereinafter Nedap). By using this manual you accept the terms of this disclaimer.

Nedap has made every effort to ensure that this manual is accurate. Nedap accepts no liability for any inaccuracies or omissions in this manual nor for any damages arising from or related to its use.

No data published in this manual may be reproduced or published in any form or by any means without the prior written consent of Nedap. Information in this manual is subject to change without notice and does not represent any commitment on the part of Nedap. Nedap does not assume any obligation to update the information in this manual after publication and reserves the right to make improvements to this manual and/or to the products described in this manual at any time without notice. If you find information in this manual that is incorrect, misleading or incomplete, we would appreciate your comments and suggestions.

2 Safety

2.1 General safety

Before installing or using the PowerRouter, read all of the instructions and alerts on the hardware and in the user and installation manual.



WARNING

The local output is floating if the system is not connected to the public grid

2.2 PowerRouter

There are two labels on the PowerRouter (figure 1):

- A warning label with battery warnings.
- A type label that provides technical specifications.



The image shows an example of the labels. The labels may be different depending on the PowerRouter type.

2.3 Local grid



DANGER

The local grid delivers electrical power (230 V, 50 Hz).



WARNING

As an extra safety measure it is required that a 2-pole emergency switch is installed at the AC LOCAL OUT connection (if used). This emergency switch must be connected in accordance with the UPS-safety standard.

2.4 Public grid



DANGER

The AC grid delivers electrical power (230 V, 50 Hz).

 **WARNING**

Before you connect the PowerRouter to the Public AC grid, contact the local utility company. They have to confirm that it is allowed to connect the system.

2.5 Solar panels

 **DANGER**

Solar panels produce electrical power when exposed to light and can cause an electric shock, energy, or fire hazard.

 **WARNING**

Series fuse protection may be required, depending on the type and configuration of the solar panels used in the system.

2.6 Batteries

 **DANGER**

Batteries deliver electric power and can cause an energy or fire hazard when they are shorted, or wrongly installed.

 **WARNING**

- Series fuse protection is required for the 24V lead-acid batteries. (48V Li-ion batteries have fuse protection inside.)
 - Batteries must be located in a designated battery area. A battery area must comply with the local regulations. This is because of the dangers of hydrogen gas and battery acid.
 - Explosive gasses. Prevent flames and sparks. Provide adequate ventilation during charging.
-

 **CAUTION**

As a feature the 24V lead-acid batteries are equipped with a battery temperature sensor, the PowerRouter uses the sensor input to control charging of the batteries. If batteries become too hot, the PowerRouter will stop charging the batteries. (48V Li-ion batteries do not need the battery temperature sensor.)

3 General description

3.1 The PowerRouter - intended use

The PowerRouter is a DC to AC solar inverter, designed for indoor use. It is designed for use with solar panels, connection to the grid, and battery storage to optimise self-use. In case of a grid failure, the AC local out may supply backup power to the connected load. For more information visit www.PowerRouter.com.

The PowerRouter is compliant with the following standards:

- 2004/108/EC (EMI)
- 2006/95/EC (low voltage directive)



CAUTION

The PowerRouter has no servicable parts inside.

3.1.1 Internet connection

When the PowerRouter is connected to the internet the myPowerRouter.com web portal provides detailed system information (for example performance, profit) of your PowerRouter. The PowerRouter can even be remotely updated with new firmware containing the latest features, so the system is always kept up to date.

3.1.2 PowerRouter software installation tool

The software installation tool helps you to initialize the PowerRouter, make advanced setting, and update the PowerRouter firmware if applicable.

Before you can use the software installation tool, you must install the software on your computer. You can download the software installation tool from the website: www.PowerRouter.com. The software installation tool includes the latest available firmware version, so no additional downloads are required.



You can download the PowerRouter software installation tool, driver, and guideline via the PowerRouter website. You need your login details for this website. You can request login details via www.PowerRouter.com. Check the website regularly for updates to the PowerRouter software installation tool.

3.2 1-phase sensor (accessory PRA1SENSE)

With the signal from the 1-phase sensor, the PowerRouter determines the energy consumption with the public grid on one phase. With the 1-phase sensor the consumption of self generated solar energy is maximized. The 1-phase sensor is delivered with the PowerRouter SB models.

3.3 3-phase sensor (accessory PRA3SENSE)

With the signal from the 3-phase sensor, the PowerRouter determines the energy consumption with the public grid for a 3-phase system, and compensates on 1-phase if a compensating electric meter is used. With the 3-phase sensor the consumption of self generated solar energy is maximized. The 3-phase sensor can be ordered via your local Business Partner.

3.4 External relay (accessory PRA1RLY)

You can use the external relay to:

- Setup a backup power supply (figure 9).

If the public grid fails, the external relay is energised. The switch over to the local AC grid is done via one of the user-selectable relays (K201 / K202) of the PowerRouter.

- Energy management (figure 10).

If the amount of solar energy fed to the public grid exceeds the programmed value, the PowerRouter can switch on additional loads via the external relay. How long the load stays switched on can be programmed in the PowerRouter, via advanced settings in the software installation tool.

- Isolate the PowerRouter from the public grid by a ripple control receiver (figure 13).

The ripple control receiver is not included. The disconnection is according to the German directive EEG2012. Only the disconnect contacts of the relay are used.

The external relay can be ordered via your local Business Partner.

3.5 Wireless Energy Management Kit (accessory PRA1WEMK)

The Wireless Energy Management Kit can be used with PowerRouter products that support energy management. If the amount of solar energy fed to the public grid exceeds the programmed value, the PowerRouter can switch on additional loads via the Wireless Energy Management Kit. The Wireless Energy Management Kit is available in several country dependent versions and can be ordered via your local Business Partner. The Wireless Energy Management Kit contains a:

- Binary input module (Eaton CBEU-02/xx).
- Wireless plug-in actuator (Eaton CSAP-01/xx).

3.6 Batteries

The PowerRouter SB models function with any 24V lead-acid batteries. The SBi models function with 48V Li-Ion batteries. Proper settings can be made via advanced settings in the software installation tool.



CAUTION

Never exchange 24V batteries with 48V batteries or vice versa.



Always check the specifications of the supplier, before making the settings.

3.7 Battery temperature sensor

The battery temperature sensor is installed on the 24V lead-acid batteries. The PowerRouter uses the sensor input to optimise charging of the batteries. When the batteries overheat, the PowerRouter stops charging the batteries. Proper settings can be made via advanced settings in the software installation tool.



48V Li-ion batteries do not need the battery temperature sensor.

4 Installation

4.1 Check the contents of the PowerRouter box

The PowerRouter box must contain the following:

- The PowerRouter.
- Wall-mounting bracket.
- Set of manuals, including the drill template.
- 1-phase sensor
- Battery temperature sensor (only for PowerRouter SB).
- Clip-on ferrite core for the UTP cable (Internet).
- Cable gland (for installation in Italy).
- Clip-on ferrite core for the digital input (for installation in Italy).

4.2 Determine the mounting location

The installation location of the PowerRouter must meet the following:

- The PowerRouter must be mounted indoors.
- Mount the PowerRouter as close as possible to the meter cupboard.
- Do not mount the PowerRouter in direct sunlight.
- Do not mount the PowerRouter during periods of precipitation or high humidity (>95%). Moisture trapped within the location may cause corrosion and damage to the electronic components.
- When the internal temperature is too high, derating will occur. The PowerRouter reduces the power output if the internal temperature becomes too high.
- The location is not accessible for children.
- The PowerRouter emits a slight hum during operation. This noise is normal and has no effect on performance, but it can be disturbing if the unit is installed on a wall in a living area, on the outside of a wall that is near a living area, or on certain types of materials (thin wood panels or sheet metal).
- The wall should be within $\pm 5^\circ$ vertical.
- The mounting surface must be able to support the weight of the PowerRouter (21.5 kg).
- The type information sticker must be visible after mounting the PowerRouter (figure 1). The sticker contains the serial number which is the login code for the install wizard, the software installation tool and to register at www.myPowerRouter.com for logging and monitoring.
- The outside dimensions of the PowerRouter are 765 x 502 x 149 mm (W x H x D).
- The PowerRouter must be installed with 300 mm clearance at the top and bottom of the unit.
- If multiple PowerRouters are stacked there must be 800 mm of clearance between each PowerRouter.

**DANGER**

-
- Do not mount the PowerRouter on or underneath flammable construction materials.
 - Do not mount the PowerRouter in areas where highly flammable materials are stored.
 - Do not mount the PowerRouter in areas where there is a danger of explosion.
-

**WARNING**

To prevent electric shock or other injury, check for existing electrical or plumbing installations in the walls before drilling the holes for the PowerRouter.

**CAUTION**

-
- Ensure that there is sufficient clearance for the airflow around the PowerRouter! Local regulations may require larger working clearances.
 - If you mount the PowerRouter in a cabinet, closet or other relatively small enclosed area, sufficient air circulation must be provided in order to dissipate the heat generated by the unit.
-

4.3 Mount the PowerRouter

The PowerRouter is shipped with a wall-mounting bracket that is suitable for use on most walls.

To mount the PowerRouter:

1. Use the drill template provided with the PowerRouter to drill the holes for the wall-mounting bracket. (Follow the illustrated instructions on the drill template, figure 2.)
2. Mount the wall-mounting bracket.
3. Mount the PowerRouter.
4. Open the lower front cover.
5. Mount the additional screws (use a screwdriver with a blade-length of at least 160 mm).

4.4 Connect the AC grid

See figure 5 for the connection overview.

1. Install an AC Disconnect Switch between the PowerRouter and the AC grid.
2. Strip the insulation off the wires. To prevent overheating of the wires, you must use wires with a conductor size of 4 mm².
3. Pass the wires through the strain-reliefs at the bottom of the PowerRouter.
4. Connect the earth (≡) according local regulations.
5. Connect the phase (L) and neutral (N) wire from the AC grid to the AC disconnect switch, and from the AC disconnect switch to the GRID terminal on the PowerRouter.
6. Tighten the strain-reliefs with a torque between 1.2 Nm and 1.5 Nm.

**WARNING**

Before you connect the PowerRouter to the Public AC grid, contact the local utility company. They have to confirm that it is allowed to connect the system.

4.5 Connect the solar panels

See figure 14 for the overview of the solar panel connections

1. Make sure the DC Disconnect Switch on the PowerRouter is OFF.
2. Verify that the DC voltage and current of your solar installation do not exceed the maximum values specified on the type plate of the PowerRouter (600 VDC, 15 A).
3. Check the polarity of the solar panel string by performing a voltage measurement.
4. Use a suitable tool to attach the MC4 plug to the solar panel string wires. Use copper wire (4 mm²) for all wiring from the solar panel string to the PowerRouter. Only use solid or stranded wire. Do not use fine stranded wire.
5. Connect one string to the left input terminals (use mating MC4 connectors).
6. If applicable connect the second string to the right input terminals (use mating MC4 connectors).

**DANGER**

The wires from the solar panels are always energised.

**CAUTION**

- Do not connect a single solar panel string to both solar panel string terminals simultaneously (parallel connection).
 - Do not connect a single solar panel string to both solar panel string terminals in series.
 - To prevent static charge you must ground the supporting frame of your solar panels. Read the instructions of the manufacturer.
 - Do not connect multiple AC local outputs parallel.
 - Do not connect multiple AC local outputs in 3-phase.
-



The PowerRouter PR30SB model has one solar panel string input.

4.6 Connect the 24V lead-acid batteries

See figure 5 for the connection overview.

1. Install a Battery Disconnect Switch (2-pole isolation) between the PowerRouter and the batteries. Use battery cables with a cross sectional area of 70 mm² to 95 mm² and a maximum length of 2.5 m per cable.
2. Install a fuse (300 A slow-blow) in series with the positive battery cable. It must be installed on a fixed surface, as close as possible to the battery.
3. Strip approximately 25 mm of insulation from the cable.
4. Insert the cable into the terminal of the PowerRouter (red to the positive terminal, black to the negative terminal).
5. Tighten the cable connection with a torque between 15 Nm and 20 Nm.
6. Use cable lug (eyelet terminal) on the other end of the battery cable.
7. Insulate the battery poles.
8. Clean the surface where you will place the temperature sensor.
9. Stick the self-adhesive battery temperature sensor onto the battery near the (+) pole.
10. Connect the sensor wires to the TMPS (red wire) and GND (black wire) terminals of the PowerRouter.



WARNING

- Batteries must be located in designated battery areas, and must comply with the local requirements. This is because of a possible build-up of hydrogen gas and battery acid.
- Do not smoke or bring open flames near hydrogen gas.



CAUTION

- Insulate the battery poles to prevent inadvertent shorting. Shorted poles may lead to sparks, fire hazard, or damage to the batteries.
- Miswiring can cause damage to the PowerRouter. Read the label on the battery.
- Never exchange 24V batteries with 48V batteries.

4.7 Connect the 48V Li-ion batteries

See figure 6 for the connection overview.

1. Use battery cables with a cross sectional area of 35 mm² to 50 mm² and a maximum length of 2.5 m per cable.
2. Strip approximately 25 mm of insulation from the cable.
3. Insert the cable into the terminal of the PowerRouter (red to the positive terminal, black to the negative terminal).
4. Tighten the cable connection with a torque between 15 Nm and 20 Nm.
5. Use cable lug (eyelet terminal) on the other end of the battery cable.
6. Insulate the battery poles.
7. Connect a CAT5e UTP cable, with the same length as the battery cables, between the PowerRouter Data 1 port and the 48V LI-ion battery unit. (The maximum length of the cat5e UTP cable is 10 m.)

**WARNING**

- Batteries must be located in designated battery areas, and must comply with the local requirements.
- To prevent overheating of the contacts, you must tighten all screws and bolts according to the manufacturer's recommendation.

**CAUTION**

- Insulate the battery poles to prevent inadvertent shorting. Shorted poles may lead to sparks, fire hazard, or damage to the batteries.
- Miswiring can cause damage to the PowerRouter. Read the label on the battery.
- Never exchange 48V batteries with 24V batteries.



check www.PowerRouter.com for supported Li-ion batteries.

4.8 Connect a self-use sensor

4.8.1 Connect the 1-phase sensor (accessory)

See figure 3 for the connection overview.

1. Remove the protective cap from the PowerRouter's CANBUS connector.
2. Place the 1-phase sensor around the phase wire (L) which is going to the grid. It must be the same phase to which the PowerRouter is connected. The arrow on the sensor must point away from the PowerRouter.
3. Connect the 1-phase sensor cable to the UTP coupler, or directly to the PowerRouter.
4. If necessary connect a CAT5e UTP cable, with a maximum length of 10 meters, between the PowerRouter CAN port and the UTP coupler.

4.8.2 Connect the 3-phase sensor (accessory)

See figure 4 for the connection overview. The sensor is configured by the PowerRouter and requires no setup; only hard wiring is required.

1. Disconnect the PowerRouter from the Public AC grid.
2. Mount the 3-phase sensor in the position as shown in figure 5
3. Set the 3-phase sensor switch in the 'I' Position.
4. Connect the 3-phase sensor in accordance with the "3P.n" configuration.
5. Connect the 1 meter sensor cable to the 3-phase sensor.
 - a. Green/white wire -> sensor terminal 41.
 - b. Green wire -> sensor terminal 42.
 - c. Orange/white wire -> sensor terminal 43.

6. Place the ferrite core (4) with one loop in the cable. The ferrite core must be within 10 cm of the PowerRouter.
7. Insert the RJ45 plug at the end of the sensor cable into the PowerRouter CAN port. A CAT5e network cable, with a maximum length of 25 meters, may be used to extend the connection (RJ45-connector type: T-568B).
8. After initialising (section 4.13), check the PowerRouter display for correct operation of the sensor – “Service menu –Status – Sensor”. If correct, “OK” will appear on the display (This may take up to 3.5 minutes after start-up).

**CAUTION**

Make sure the sensor is correctly installed. Wrong installation will result in no self-use maximization, or will deplete the battery.

4.9 Connect the external relay (accessory)

4.9.1 Connect the external relay for energy management

See figure 10 for the connection overview.

1. Connect the external relay. Use one of the user-selectable contacts K201 / K202.
2. Program the user-selectable contacts K201 / K202 via advanced settings in the software installation tool (see chapter 5).

**CAUTION**

The load that is connected to the relay must be 1-phase.



For this function the value for energy export to the grid must be >0. If the 1-phase sensor is installed the energy management will be done based on the sensor input, otherwise the AC grid connection will be used.

4.9.2 Connect the external relay to isolate the PowerRouter from the public grid

This option is only applicable for Germany (directive EEG2012). See figure 13 for the connection overview.

1. Connect the external relay.
2. Program the user-selectable contacts K201 / K202 via advanced settings in the software installation tool (see chapter 5).

4.9.3 Connect the external relay for a backup power supply

See figure 9 for the connection overview.

1. Connect the load to the external relay.
2. Strip the insulation off the wires. Use wires with a conductor size of 4 mm².
3. Pass the wires through the strain-reliefs at the bottom of the PowerRouter.
4. Connect the phase (L) and neutral (N) wire from the external relay to the AC LOCAL OUT terminal on the PowerRouter.
5. Install an AC Disconnect Switch between the AC local out and the external relay.

6. Tighten the strain-reliefs with a torque between 1.2 Nm and 1.5 Nm.
7. Connect the external relay control wires. Use one of the user-selectable contacts K201 / K202.
8. Program the user-selectable contacts K201 / K202 via advanced settings in the software installation tool (see chapter 5).

**DANGER**

The “local out” output is only suitable for 1-phase loads. Connecting 1-phase of a 3-phase load, may lead to damage to the 3-phase load.

**CAUTION**

- Batteries will not be charged if the local out has a continuous load with an average load of 80% of the rated power. If the batteries are not charged they may be severely damaged and the lifetime may be reduced. Make sure the batteries get charged by reducing the connected loads or intermitted use.
 - Connect the earth (⊕) according local regulations.
-

4.10 Install the PRA1WEMK

See figure 17 for the connection overview and figure 18 for installation details.

1. Open the binary input module.
2. Connect two wires to the connection AA of the binary input module.
3. Fix the location of the wires with a cable tie.
4. Remove the foil (1) from the battery.
5. Press the button (2) once.
The LED (3) flashes once and stays on for a few seconds.
6. While the LED is on press the button (2) once.
The LED (3) flashes twice and stays on for a few seconds. If the LED is off the configuration is completed.



If the LED flashes three or four times, repeat the step above until the LED flashes twice.

7. Press the button (4) once (<0.5s) to set the wireless plug-in actuator in teaching mode.
8. Short circuit the contacts AA and keep it this way. This simulates activation of the binary input module, the wireless plug-in actuator should make a clicking sound twice (switch on).
9. Press the button (4) once (<0.5s) to set the wireless plug-in actuator in normal mode.
10. Remove the short circuit from the contacts AA.
11. Install the binary input module with the double sided tape. The binary input module must be installed at least 300mm away from the PowerRouter.



It is advised to install the Binary input module in a standard mounting box (plastic).

12. Connect the two wires to the PowerRouter programmable contact K201.
13. Install the cover on the binary input module.

14. Install the wireless plug-in actuator in the desired wall outlet.
15. Program the contact K201/K202 for energy management (refer to chapter 5).

**CAUTION**

The maximum load of the wireless plug-in actuator is 8A.

**CAUTION**

The maximum range of the binary input module is 50m. Walls, ceilings and metal constructions will limit the range. (For details refer to the manuals delivered with the binary input module and wireless plug-in actuator.)



- *For this function the value for energy export to the grid must be >0. If the 1-phase sensor is installed the energy management will be done based on the sensor input, otherwise the AC grid connection will be used.*
 - *Additional xComfort products that can be ordered at Eaton. For installation of additional xComfort components refer to manual delivered with the product, or contact your local Eaton dealer.*
-

4.11 Connect the additional cable (Italy)

The additional cable is only applicable for Italy (directive CEI-021). See figure 16 for the connection overview.

1. Remove the plate from the knock-out hole (1).
2. Place the cable gland (4) from the bottom through the hole.
3. Fasten the cable gland with the nut (3) on the inside of the PowerRouter.
4. Slide the cable through the cable gland.
5. Connect the cable to the connector (2).
6. Fasten the cable-nut (5).
7. The cable can be connected to an external receiver from the power company. In figure 16;
Contact closure A (blue) activates the remote trip.
Contact closure B (green) activates the move frequency band signal.
C (orange) and D (brown) are not connected, for further use.
8. Install the clip-on coil (6) on the cable within 10 cm of the powerrouter.

4.12 Switch on the system

1. Close the lower front cover.
2. For 24V lead-acid batteries set the external battery disconnect switch to on.
For 48V Li-ion batteries switch on the unit.
3. Set the solar switch, on the PowerRouter, to on.
4. Set the external AC disconnect switch to on.
5. Switch on the PowerRouter (switch on the display).

4.13 Initialise the PowerRouter

The PowerRouter must be initialised by setting system parameters. After setting the parameters, the PowerRouter is ready to use. There are two methods to set the system parameters.

4.13.1 Installation wizard (on the display)

1. The installation wizard starts automatically the first time you switch on the PowerRouter.
2. Use the buttons on the PowerRouter display to go through the installation wizard screens and make changes.



CAUTION

The installation wizard only asks for basic battery settings, based on these settings the PowerRouter updates other battery settings overwriting any customized battery settings. Any customized battery settings will be lost.



If you start the installation wizard manually, you must enter a password. The password is the last four digits of the serial number on the type plate at the bottom of the PowerRouter.

4.13.2 Software installation tool (for advanced settings)

1. Connect a PC, with the software installation tool, to the PowerRouter's USB port (use a USB cable as shown in figure 8).
2. Use the software installation tool to set the system parameters.



CAUTION

The software installation tool has a menu option re-initialize. If you use this wizard, it only asks for basic battery settings, based on these settings the PowerRouter updates other battery settings overwriting any customized battery settings. Any customized battery settings will be lost.



You can download the PowerRouter software installation tool, driver, and guideline via the PowerRouter website. You need your login details for this website. You can request login details via www.PowerRouter.com. Check the website regularly for updates to the PowerRouter software installation tool.

4.13.3 Run the self test (Italy)

The self-test is only applicable for Italy (directive CEI-021). If the country is set to Italy, the self-test is available via the service menu on the display.

The Italy Self Test is meant to check the upper and lower limits of the AC voltage and AC frequency at which the PowerRouter will disconnect from the grid. If the test fails, the PowerRouter is not allowed to connect to the grid.



The example displays below show the self test OK. If the test fails the display will show *Selftest fail*.

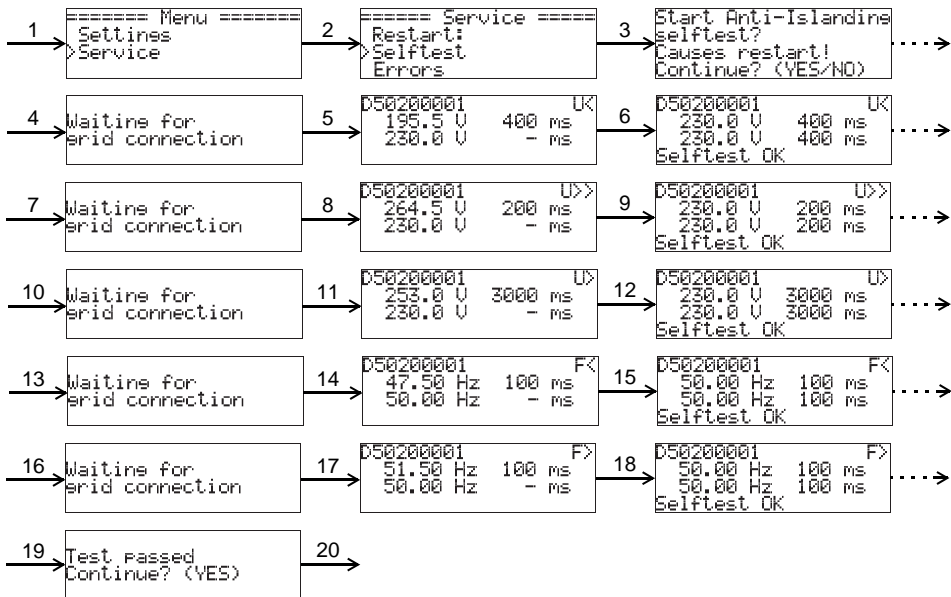

1. Press *yes*, and use up/down to select *Service*.
2. Press *yes*, and use up/down to select *Selftest*.
3. Press *yes* to go to the *Selftest*.
4. Press *yes* to continue, or *no* to cancel.
5. Wait until the grid is connect and the voltage lower trip test starts.
6. Wait until the test is finished (*Selftest OK* or *Selftest fail*).
7. Press *yes* to continue.
8. Wait until the grid is connect and the voltage upper trip test starts.
9. Wait until the test is finished (*Selftest OK* or *Selftest fail*).
10. Press *yes* to continue.
11. Wait until the grid is connect and the average voltage upper trip test starts (takes 10 minutes).
12. Wait until the test is finished (*Selftest OK* or *Selftest fail*).
13. Press *yes* to continue.

14. Wait until the grid is connect and the frequency lower trip test starts.
15. Wait until the test is finished (*Selftest OK* or *Selftest fail*).
16. Press *yes* to continue.
17. Wait until the grid is connect and the frequency upper trip test starts.
18. Wait until the test is finished (*Selftest OK* or *Selftest fail*).
19. Press *yes* to continue.
20. The display should show *Selftest passed*. Press *yes* to continue.

**CAUTION**

If the test is cancelled the PowerRouter reacts as if the selftest failed.



If the PowerRouter switches off during the selftest, or the display shows an error, restart the PowerRouter and redo the test. If the selftest failes the second time contact your local Bussiness Partner.

4.14 Connect the PowerRouter to the internet

**CAUTION**

Install the clip-on coil on the UTP cable within 10 cm of the powerrouter.

4.14.1 Connect to an internet router

An example of a connection is shown in figure 11. The PowerRouter can be connected to any of the available ports. The numbers in the drawing are:

1. Internet Router.
2. Connected computers.
3. CAT5e UTP cable.
4. PowerRouter.
5. ADSL, ISDN, or cable connection.
6. Power adapter for the internet router.

4.14.2 Connect via a switch to an internet router

An example of a connection is shown in figure 12. The PowerRouter can be connected to any of the available ports of the switch. The numbers in the drawing are:

1. Internet Router.
2. CAT5e UTP cable.
3. Ethernet switch.
4. PowerRouter.
5. Connected computers.
6. Internet modem.
7. ADSL, ISDN, or cable connection.
8. Power adapter for the internet router.

4.14.3 Connect to a wireless access point

An example of a connection is shown in figure 15. The numbers in the drawing are:

1. Internet Router.
2. ADSL, ISDN, or cable connection.
3. Power adapter for the internet router.
4. Wireless access point.
5. CAT5e UTP cable.
6. PowerRouter.



CAUTION

-
- You must place the clip-on coil on the UTP cable.
 - The wireless access point must support wireless client function, and it must have a RJ45 connection. If in doubt consult your supplier.
 - The PowerRouter cannot connect to the internet via a proxy server.
-

4.14.4 Register the PowerRouter on www.myPowerRouter.com

1. Make sure you have the Part.no., Serial no., and Control code available as mentioned on the type label of the PowerRouter (figure 1).
2. Check the internet connection via menu > service > status > internet connection. The display should show OK.
3. Go to a computer and open www.myPowerRouter.com.
4. In the login screen click *New user* (figure 19).
5. Fill out the Part.no., Serial no., Control code, and click *Register* (figure 20).
6. Fill out the fields in the window (figure 21), and click *Continue*.
7. Fill out the fields in the window (figure 22), and click *Continue*.
8. You will receive a confirmation e-mail.

4.14.5 Register additional PowerRouters on one login

You can register two additional PowerRouters on the same login. To do this:

1. Login on www.myPowerRouter.com.
2. Click *My PowerRouter*.
3. Click *New PowerRouter* (figure 23).
4. Fill out the Part.no., Serial no., Control code, and click *Register PowerRouter* (figure 24).



CAUTION

-
- The PowerRouter internet connection will not work if a proxy server is being used.
 - Do not use the AC local out of the PowerRouter to provide power to the internet router, or internet switch, the connection will be lost during a reset.
-



-
- *The PowerRouter only uses internet port 80. This is the default setting on most networks.*
 - *The PowerRouter needs a DHCP server within the network. This should be provided by the internet router or the internet switch.*
 - *To test the connection, connect a PC to the connection that you will use for the PowerRouter. Open a web page. If the web page opens, the connection works.*
 - *The maximum length of the CAT5e UTP cable is 20 meters. If you need to clear a longer distance, you can use an additional router, and an additional cable of 20 meters.*
 - *Powerline communication may result in an unreliable internet connection.*
-

5 Software installation tool

5.1 Introduction

After the installation with the software installation tool it is possible to make advanced settings to further optimise the PowerRouter.

Below you find an overview of features that are available in the software installation tool, under advanced settings. Each feature has a short description, for detailed information refer to the help available in the software installation tool or the guideline (download from www.PowerRouter.com).



CAUTION

The software installation tool has a menu option re-initialize. If you use this wizard, it only asks for basic battery settings, based on these settings the PowerRouter updates other battery settings overwriting any customized battery settings. Any customized battery settings will be lost.



You can download the PowerRouter software installation tool, driver, and guideline via the PowerRouter website. You need your login details for this website. You can request login details via www.PowerRouter.com. Check the website regularly for updates to the PowerRouter software installation tool.

5.2 Display settings

5.2.1 Backlight

Sets the time the PowerRouter's backlight stays on after pressing a button.



5.2.2 Display

Select the information that will be shown by default in the display of the PowerRouter.



5.2.3 Language

Select the language of the display of the PowerRouter.



5.3 PowerRouter settings

5.3.1 Scenario

Change the scenario of the PowerRouter. This option is not yet available, it is reserved for future use.



5.3.2 Alarm 1 / Alarm 2

The PowerRouter is provided with 2 user-selectable relays referred as K201 and K202. This chapter describes the different alarms you may assign. After specifying the alarm it needs to be assigned to the relay icon, appearing next to the alarm icon in the installation tool. The relay icon can be selected after configuring the alarm.

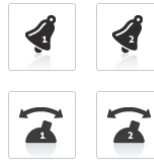

Off

This is the default selection for an alarm relay. It is off or not used.

Grid voltage alarm

When the grid voltage is outside of the desired range the alarm relay is inactive. This can be used to switch on loads or sound an alarm when the grid voltage is out of range.

For example to protect sensitive loads against high voltage. Or to switch on additional loads when the grid voltage is high. Which is usually an indication of high feed-in power.

Battery State of Charge (SoC)

Alarm based on the battery state of charge. The alarm relay is activated when the battery State of Charge is outside the specified range.

Battery temperature alarm

Alarm based on the temperature of the battery pack. The alarm relay is activated when the temperature of the battery pack is above the specified range.

Battery voltage alarm

Alarm based on the voltage of the battery pack. The alarm relay is activated when the battery voltage below the specified range.

Grid connection alarm

Alarm based on whether the system is connected to the grid. The relays are inactive if the system is in standby and no grid is available to power the relays.



CAUTION

This alarm is not to be used for backup functionality.

Energy management

Switch on additional loads when a surplus of solar energy is available to increase the self-use.

Self-use with backup

Alarm based on whether the system is connected to the grid. When disconnected from the grid, the PowerRouter will switch to backup mode.

5.3.3 Standby

Select that the PowerRouter can go in standby. The PowerRouter will go in to standby when there is no solar power or battery power available.



5.3.4 Standby timer

Select a time interval, in which the PowerRouter goes to standby.



5.4 Grid

5.4.1 Country

Set the country grid settings for a specific country.



CAUTION

It is not allowed to select another country, than the country the PowerRouter will be installed.

5.4.2 EEG 2012

Set the dedicated parameters to your installation size to comply with the German EEG 2012 regulation.



5.4.3 VDE 4105

Change the grid settings to comply with the VDE 4105 per local utility requirements.



5.4.4 Dynamic feed-in limiter

With the Dynamic feed-in limiter the output of the system can be adjusted. You can:

- Limit the output of the system.
- Limit the output to the grid after the point where the load is connected to the grid.



5.5 Battery pack

You can change:

- Type of battery pack.
- Size of battery pack (only for 24V lead-acid batteries).
- Depth of Discharge for self-use.
- Depth of Discharge during grid failures.



CAUTION

Wrong settings may harm the batteries.

5.5.1 Battery charging

This option is not available for 48V Li-ion batteries. For 24V lead-acid batteries you can change:

- The charging procedure to float charging.
- The absorption voltage and float voltage.
- The charge current.



CAUTION

Wrong settings may harm the batteries.

5.5.2 Maintenance charge

Set the interval of when to perform the maintenance charge.



5.5.3 Self-use battery settings

Change specific battery setting to optimise self-use. With the battery power limiter enabled, the battery will not be used to compensate peak loads, but only for the base load.



5.5.4 Wintermode

Wintermode controls the usage of the battery module during the winter period.



6 Operation

6.1 Display menu

Open the menu

- Press any button on the display to open the menu.

Navigate through the menu

- Use the UP/DOWN buttons to navigate through the menu.
- Use YES to open the selected item.
- Use NO to return to the previous item.

Select and change settings

- Use YES to change a selected setting.
- Use the UP/DOWN buttons to change the selected setting.
- Use YES to confirm the changed setting.
- Use NO to cancel the change.

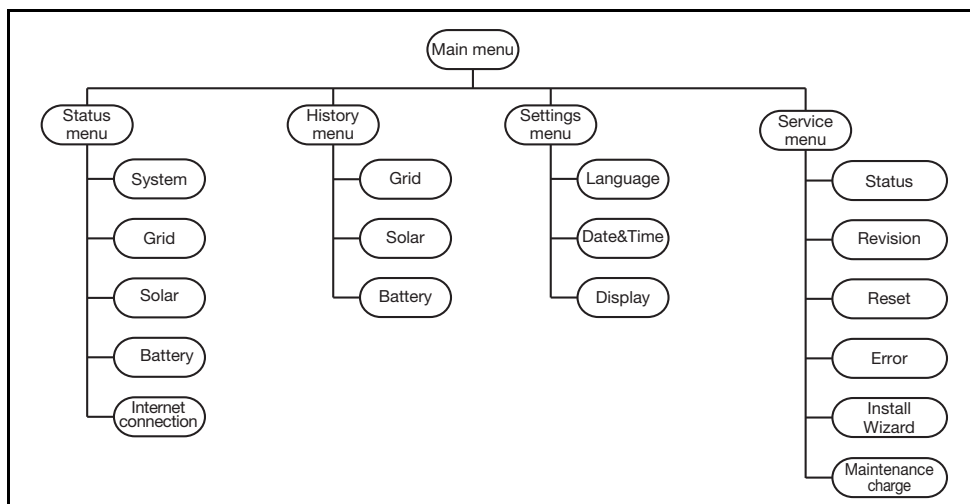

7 Troubleshoot

7.1 Troubleshooting

If you encounter difficulty with the operation of your PowerRouter, follow the steps below:

- Check the LED status.
- Check the error message on the LCD display, and the error history.
- If the difficulty remains, contact your installer/dealer.

Collect the following information before you contact your installer or dealer (figure 1):

- Model number
- Serial number
- Brief description of the problem
- LED status
- Displayed error message
- Error history
- Software version and ID number

7.2 Check the LED status

When an error has occurred the LEDs will either be OFF or FLASHING as follows:

PowerRouter state	Operational (blue)	Charging (blue)	Grid (blue)	Error (red)
Normal Operation	on	*	*	off
Standby	blinking	off	off	off
Not initialised	blinking	off	off	blinking
System check	off	on	*	off
Soft error	on	*	*	on
Hard error	off	off	off	blinking
Firmware update**	off	off	*	on
Validating the grid	*	*	blinking	*
Grid connected	*	*	on	*
Fast charging batteries	*	blinking	*	*
Charging batteries	*	on	*	*
Using battery power	*	off	*	*

* The LED can be on, blinking, or off.

** The PowerRouter is receiving / installing an update, this process may last for 25 minutes. The display will show a progress bar from 0% to 100%. During this time you must not do any other actions on the PowerRouter.

7.3 Check the error messages

The PowerRouter shows the latest error message on the display. The last ten error messages are stored in the error history. For possible solutions see section 7.5.

Most errors are cleared automatically by the system if the error condition disappears. If an error message does not clear itself, press the NO button for at least 3 seconds to clear the error.

7.4 Error explanation

7.4.1 Hard error

When a hard error occurs the PowerRouter goes into a safe mode and will not function until the user has turned the system off and on or a reset is performed. A hard error is indicated when the error LED is flashing.

7.4.2 Soft error

When a soft error occurs the module in which the error originated will go into a safe mode. Other modules in the PowerRouter will continue to operate. The PowerRouter can recover from the error automatically. A soft error is indicated when the error LED is on.

7.4.3 Error code

Example: **P027-H**

P The first letter indicates where the error originated within the PowerRouter

P - Platform

S - Solar module

B - Battery module

G - Grid module

027 The number indicates which error has occurred

H The second letter indicates the level of the error that occurred

H - Hard error

S - Soft error

7.5 Errors



Check www.PowerRouter.com for the latest version of the errorlist.

Error	Level	Explanation	Action
P027-H P028-H P029-H G025-H	Hard	A grid error has occurred	<ul style="list-style-type: none"> Restart the system (section 7.6.1) The system should recover from the error after the restart Contact your dealer if this error occurs frequently
P058-H	Hard	After a firmware update one of the modules has an incompatible firmware version	<ul style="list-style-type: none"> Contact your dealer for the correct firmware package Update the firmware of the system with the correct version Restart the system (section 7.6.1)
P073-H	Hard	Last grid connection self test (italy only) has failed	<ul style="list-style-type: none"> Restart the self test, succesful completion of the self test clears this error
P081-H	Hard	The installation wizard or installation tool failed to write the anti-islanding settings to the PowerRouter	<ul style="list-style-type: none"> Restart the system (section 7.6.1) Run the installation tool or install wizard again Contact your dealer if this error occurs frequently
P092-H G034-H B026-H S019-H	Hard	The PowerRouter configuration is incorrect.	<ul style="list-style-type: none"> Contact your dealer if this error occurs.
P098-H G036-H B028-H S021-H	Hard	The firmware in the PowerRouter does not match the hardware.	<ul style="list-style-type: none"> Contact your dealer if this error occurs.
P100-S	Soft	There was too much load. variation during the sensor test	<ul style="list-style-type: none"> Turn off the loads connected to the same phase as the PowerRouter Restart the system (section 7.6.1)
P105-S	Soft	The PowerRouter needs a 1-phase or 3-phase sensor to operate in the selected scenario. This sensor was not detected.	<ul style="list-style-type: none"> Make sure the connection of the 1-phase or 3-phase sensor is correct and in the right position. For detailed information see the related section in this manual. Restart the system (section 7.6.1).
P106-S	Soft	The connection between the PowerRouter and the 3-phase sensor has been lost, or the 3-phase sensor has no power.	<ul style="list-style-type: none"> Check the connection between the PowerRouter and the 3-phase sensor. Check the power connection of the 3-phase sensor. Restart the system (section 7.6.1),

P111-S	Soft	The PowerRouter was not able to configure the 3-phase sensor.	<ul style="list-style-type: none"> • Make sure the 3-phase sensor is connected properly. • Make sure the 3-phase sensor is not in the locked position. • Restart the system (section 7.6.1)
P115-H	Hard	The PowerRouter cannot function correctly because some hardware modules were not detected	<ul style="list-style-type: none"> • Contact your dealer if this error occurs
P118-H	Hard	The installation wizard failed.	<ul style="list-style-type: none"> • Restart the system (section 7.6.1) • Run the installation tool or install wizard again • Contact your dealer if this error occurs frequently
G001-S G037-S	Soft	The internal temperature of the grid module (G) is too high The output power of the module is reduced	<ul style="list-style-type: none"> • Check the PowerRouter airflow (section 7.6.2) • Once the module cools down the error will disappear and normal operation will resume • Contact your dealer if this error occurs frequently
G002-S	Soft	An overvoltage occurred on the power backbone. The grid module (G) will be temporarily turned off	<ul style="list-style-type: none"> • Once the voltage drops below the safe level the error will disappear and normal operation will resume • Contact your dealer if this error occurs frequently
G003-S	Soft	An undervoltage occurred on the power backbone. The grid module (G) will be temporarily turned off (e.g. the load on the local out is higher than the power available in the PowerRouter)	<ul style="list-style-type: none"> • Make sure the loads on the local out are turned off • After one minute the error will disappear and normal operation will resume • Contact your dealer if this error occurs frequently
G007-S	Soft	The voltage level on the local out is too high in a situation where no voltage is expected	<ul style="list-style-type: none"> • If this error occurs during installation make sure the grid is connected to the "AC GRID" connection • When this error occurs during normal operation an error has occurred in connection with the anti-islanding safety requirements • Restart the system (section 7.6.1) • Contact your dealer if this error occurs frequently
G011-S	Soft	An undervoltage occurred on the local out. The local out will be temporarily turned off.	<ul style="list-style-type: none"> • Make sure the loads on the local out are turned off • After one minute the error will disappear and normal operation will resume • Contact your dealer if this error occurs frequently
G012-S	Soft	An overvoltage occurred on the local out. The local out will be temporarily turned off (e.g. a very high load connected to the local out was suddenly disconnected)	<ul style="list-style-type: none"> • Make sure the loads on the local out are turned off • After one minute the error will disappear and normal operation will resume • Contact your dealer if this error occurs frequently
G013-H	Hard	A short circuit was detected on the PowerRouter local out	<ul style="list-style-type: none"> • Make sure the loads on the local out are turned off • Check the wiring connected to the local out for a short • Restart the system (section 7.6.1)
G015-S	Soft	There was an internal communication error within the PowerRouter	<ul style="list-style-type: none"> • After one minute the error will disappear and normal operation will resume • Contact your dealer if this error occurs frequently
G023-H	Hard	The local out output was overloaded	<ul style="list-style-type: none"> • Turn off the loads connected to the PowerRouter • Restart the system (section 7.6.1)
G025-H	Hard	See P027-H	

G028-H	Hard	An error occurred on one of the internal voltage supplies of the grid module (G)	<ul style="list-style-type: none"> Restart the system (section 7.6.1) The system should recover from the error after the restart Contact your dealer if this error occurs frequently
G029-S	Soft	The grid module (G) start-up procedure failed	<ul style="list-style-type: none"> After one minute the error will disappear and normal operation will resume Contact your dealer if this error occurs frequently
G031-H	Hard	There was an overpower on the output of the PowerRouter	<ul style="list-style-type: none"> Turn off the loads connected to the PowerRouter Restart the system (section 7.6.1)
G034-H	Hard	See P092-H	
G036-H	Hard	See P098-H	
G039-S	Soft	The output power of the grid module (G) has been reduced because the grid frequency was too high	<ul style="list-style-type: none"> The error will disappear and normal operation will resume when the grid frequency is within approved limits
G040-S	Soft	The output power of the grid module (G) has been reduced because the grid voltage was too high	<ul style="list-style-type: none"> The error will disappear and normal operation will resume when the grid voltage is within approved limits
G041-S	Soft	The output power of the grid module (G) has been reduced because the 10 minute average of the grid voltage was too high	<ul style="list-style-type: none"> The error will disappear and normal operation will resume when the 10 minute average of the grid voltage is within approved limits
G043-H	Hard	Error occurred in anti-islanding settings.	<ul style="list-style-type: none"> Restart the system (section 7.6.1) Run the installation wizard or tool again and select country.
B004-S	Soft	The battery temperature sensor indicates the temperature of the batteries is too high	<ul style="list-style-type: none"> Check the ambient temperature of the room where the batteries are located. The ambient temperature of the room in which the PowerRouter is located must not exceed 40 degrees Celsius. The error will be cleared when the temperature decreases
B007-S B008-S B009-S B014-S B015-S B016-S B017-S B018-S B019-S B030-S	Soft	The internal temperature of the battery module (B) is too high The output power of the module has been reduced	<ul style="list-style-type: none"> Check the PowerRouter airflow (section 7.6.2) When the module cools down the error will disappear and normal operation will resume Contact your dealer if this error occurs frequently
B010-H B012-H	Hard	The voltage level of an internal battery module (B) circuit was out of bounds	<ul style="list-style-type: none"> Check the following: <ul style="list-style-type: none"> the battery capacity settings (with the install tool or the wizard on the display) the quality of the batteries Make sure the loads on the local out are turned off Restart the system (section 7.6.1)
B011-H B013-H B021-H	Hard	An overcurrent was detected in one of the internal circuits of the battery module (B)	<ul style="list-style-type: none"> Make sure the loads on the local out are turned off Restart the system (section 7.6.1)

B020-S	Soft	An overvoltage occurred on the power backbone. The grid module (G) will be temporarily turned off	<ul style="list-style-type: none"> When the voltage drops below the safe level the error will disappear and normal operation will resume Contact your dealer if this error occurs frequently
B024-H	Hard	The battery module (B) detected a short on the module input	<ul style="list-style-type: none"> Check the wiring of the battery to the PowerRouter Restart the system (section 7.6.1)
B026-H	Hard	See P092-H	
B028-H	Hard	See P098-H	
B038-S	Soft	There was an internal communication error within the PowerRouter	<ul style="list-style-type: none"> After one minute the error will disappear and normal operation will resume Contact your dealer if this error occurs frequently
B055-H	Hard	The battery module (B) detected an overvoltage on the module input	<ul style="list-style-type: none"> Check the wiring of the battery to the PowerRouter Restart the system (section 7.6.1)
B056-S	Soft	Battery voltage is too high	<ul style="list-style-type: none"> When the voltage drops below the limit the error will disappear. Contact your dealer if this error occurs frequently
B058-H	Hard	The battery current shunt is not present, or not detected (negative battery cable).	<ul style="list-style-type: none"> Connect the current shunt in the negative battery cable. Without the current shunt the PowerRouter cannot measure the current coming from, or going into the battery.
S002-S S023-S	Soft	The internal temperature of the solar module (S) is too high The output power of the module has been reduced	<ul style="list-style-type: none"> Check the airflow of the PowerRouter (section 7.6.2) When the module cools down the error will disappear and the normal operation will resume Contact your dealer if this error occurs frequently
S004-S	Soft	The solar string voltage connected to one or both of the inputs exceeds 600 volts.	<ul style="list-style-type: none"> Check the solar panel configuration and wiring. The error will disappear when the voltage on both strings drops below 600 volts.
S005-S	Soft	An overvoltage occurred on an internal bus of the solar module (S).	<ul style="list-style-type: none"> The error will disappear when the voltage drops below the limit. Contact your dealer if this error occurs frequently.
S007-S	Soft	An overcurrent occurred on an internal circuit of the solar module (S)	<ul style="list-style-type: none"> After ten minutes the error will disappear and normal operation will resume. Contact your dealer if this error occurs frequently.
S013-S	Soft	The output power of the solar panels exceeds 6000 watts	<ul style="list-style-type: none"> This error will disappear when the power drops below 6000 watts Contact your dealer if this error occurs frequently.
S016-S	Soft	There was an internal communication error within the PowerRouter	<ul style="list-style-type: none"> The error will disappear automatically and normal operation will resume. Contact your dealer if this error occurs frequently.
S019-H	Hard	See P092-H	
S021-H	Hard	See P098-H	
S024-S	Soft	Problem with the onboard supply voltage, or the Solar boost limiter is activated.	<ul style="list-style-type: none"> The system will recover automatically. Contact your dealer if this error occurs frequently.

7.6 Procedures

7.6.1 Restart the PowerRouter

The PowerRouter can be restarted in any of the following ways:

- Turn the system off and on with the on/off switch on the display.
- Use the restart function in the service menu.

7.6.2 Check the PowerRouter airflow

If an over-temperature condition occurs check the following:

- Make sure the ambient temperature in the room where the PowerRouter is located does not exceed 40 degrees Celsius.
- Make sure the airflow through the PowerRouter is not obstructed. Check the air output at the top and the air input at the bottom.
- Open the connection area of the PowerRouter and make sure the internal fans are turning (this step must be performed by a trained service engineer).

7.6.3 Check the internet connection

The display will show information about the internet status like: Internet connection status (ok, error, counting), Last date and time when the PowerRouter was connected to the internet, the IP number and status of the firmware distribution.

7.6.4 Look up the firmware versions and id number

Open the display menu and navigate to revision. Here you will find:

- The firmware versions of the various internal modules.
- The PowerRouter's unique identification number here.

7.6.5 Reset the PowerRouter

If the PowerRouter is not working as expected, it may help to perform a restart.



CAUTION

Notify the end-user before you do a restart. A restart of the PowerRouter can result in a temporary power failure. This means that no power will be available for the end-user. The restart takes less than 1 minute.

1. Notify the end-users that there may be a brief power interruption.
2. Open the display menu.
3. Navigate to the restart procedure.
4. Activate the restart procedure.

8 De-installation



DANGER

To safely de-install the PowerRouter, you must follow the instructions in this chapter.

8.1 De-install

To de-install the PowerRouter:

1. Switch the PowerRouter unit OFF.
2. Switch the solar disconnect switch OFF (on the bottom of the PowerRouter).
3. For 24V lead-acid batteries set the external battery disconnect switch to off. For 48V Li-ion batteries switch off the unit.
4. Switch the battery switch OFF.
5. Switch the AC switches OFF (grid and local out).
6. Wait at least 5 minutes, to ensure the unit is completely de-energised.
7. Disconnect the communication wires.
8. Disconnect any optional connections.
9. Disconnect the solar panel string wiring with the special tool (figure 7).
10. Disconnect the AC wires.
11. Disconnect the DC wires.
12. Disconnect the battery wires.
13. The PowerRouter can now be removed for disposal or repair.



DANGER

The wires from the solar panels are always energised. The voltage from a string of solar panels can be as high as 600 V. The current can be as high as 15 A.



CAUTION

- De-installation must be carried out by qualified personnel. Contact your installer/dealer.
 - 48V Li-ion batteries are indicated as dangerous goods and may require special transportation. Check the documentation of the supplier and local regulations.
-

8.2 Disposal

When the PowerRouter reached the end of its service life, or is defect beyond repair:

- Dispose of the PowerRouter according to local regulations.
- Submit the PowerRouter to a collection point for electrical and electronic waste recycling.



CAUTION

The PowerRouter must be disposed of according to local regulations.

9 Technical specifications

9.1 Technical specifications of the PowerRouter SB models

AC output	PR50SB-BS	PR37SB-BS	PR30SB-BS
Continuous output power	5000 W (DE: 4600 W)	3700 W (DE/UK/PT: 3680 W)	3000 W
AC output current	25 A (DE: 22A)	18 A	15 A
Cos Phi	1 (DE, IT: 0.9 ind. ... 0.9 cap. adjustable)		
Output voltage	230 Vac \pm 2% , 50 Hz \pm 0.2 % (180-264 Vac, 45-55 Hz , true sine wave <3% THD, single phase)		
AC performance (local out)	5000 VA (DE: 4600 VA)	3700 VA	3000 VA
Peak power (local out)	1.5 x Pnom., 10 sec. ; 1.2 x Pnom., 30 sec.		
Protection	electronic, fused		
Standby losses	< 3 W		
User interface	display with 4-button operation		
Connectivity	ethernet (RJ45), TCP/IP		
User-selectable relays	2 provided. NO/NC, 250Vac, 1 A, 24 Vdc, 5 A		

Solar panels	PR50SB-BS	PR37SB-BS	PR30SB-BS
Max. input	5.5 kWp total, 15 A per string	4 kWp total, 15 A per string	3.3 kWp total, 15 A
No. of inputs	2	2	1
No. of MPP trackers	2, fully independent	2, fully independent	1
DC disconnect switch	4-pole, 600 V, 15 A	4-pole, 600 V, 15 A	2-pole, 600 V, 15 A
Solar voltage	100-600 Vdc per string		
MPP voltage	180-480 Vdc per string	140-480 Vdc per string	220-480 Vdc per string
Solar connections	MC4		
Max. efficiency	94% (93% EU)		
Max. MPP efficiency	99.9%		

Lead-acid (wet/gel) and AGM	PR50SB-BS	PR37SB-BS	PR30SB-BS
Battery voltage range	21 - 31 Vdc		
Charge current	20 - 155 Adc, programmable	20 - 155 Adc, programmable	20 - 125 Adc, programmable
Battery capacity	min. 100 Ah, at 20A charge current		
Charging curve	3-stage adaptive with maintenance		
Short circuit protection	electronic, at max. charge current, switch off <1 sec		
Battery temperature compensation	included		
Battery voltage sense	integrated		
Current shunt	integrated		

Environmental	PR50SB-BS	PR37SB-BS	PR30SB-BS
Operating temperature range (full power)	-10 °C to +50 °C (derating to prevent overtemperature)		
Storage temperature	-40 °C to +70 °C		
Humidity	maximum 95%, non-condensing		
Regulatory approvals and standards	CE, VDE-AR-N 4105:2011-08, EEG2012, C-Tick		
Safety	EN 60950-1, EN 62109-1-2, EN 60335-2-29, EN 62040-1		
Emission	EN 61000-3-2, EN 61000-3-3, EN 61000-6-3, EN 61000-3-12		
Immunity	EN 61000-6-2, EN 61000-3-11		
Anti-islanding protection	VDE 0126.1.1, G83/1(UK), RD1699/2011(ESP), CEI0-21 (IT), AS4777 (AUS) (check www.PowerRouter.com for other country certifications)		
Warranty	five years (optional: extension to ten years)		

General	PR50SB-BS	PR37SB-BS	PR30SB-BS
Dimensions (W x H x D)	765 x 502 x 149 mm		
Protection category	indoor use (IP20)		
Weight	21.5 kg		
Topology	galvanically isolated transformer		
Cooling	forced airflow		



All specifications apply at 25°C unless stated otherwise.

9.2 Technical specifications of the PowerRouter SBi models

AC output	PR50SBi-BS	PR37SBi-BS
Continuous output power	5000 W (DE: 4600 W)	3700 W (DE/UK/PT: 3680 W)
AC output current	25 A (DE: 22A)	18 A
Cos Phi	1 (DE, IT: 0.9 ind. ... 0.9 cap. adjustable)	
Output voltage	230 Vac ± 2% , 50 Hz ± 0.2 % (180-264 Vac, 45-55 Hz , true sine wave <3% THD, single phase)	
AC performance (local out)	5000 VA (DE: 4600 VA)	3700 VA
Peak power (local out)	1.5 x P _{nom.} , 10 sec. ; 1.2 x P _{nom.} , 30 sec.	
Protection	electronic, fused	
Standby losses	< 3 W	
User interface	display with 4-button operation	
Connectivity	ethernet (RJ45), TCP/IP	
User-selectable relays	2 provided. NO/NC, 250Vac, 1 A, 24 Vdc, 5 A	

Solar panels	PR50SBI-BS	PR37SBI-BS
Max. input	5.5 kWp total, 15 A per string	4 kWp total, 15 A per string
No. of inputs	2	2
No. of MPP trackers	2, fully independent	2, fully independent
DC disconnect switch	4-pole, 600 V, 15 A	4-pole, 600 V, 15 A
Solar voltage	100-600 Vdc per string	
MPP voltage	180-480 Vdc per string	140-480 Vdc per string
Solar connections	MC4	
Max. efficiency	94% (93% EU)	
Max. MPP efficiency	99.9%	

Li-ion	PR50SBI-BS	PR37SBI-BS
Battery voltage range	42 - 56 Vdc	
Charge current	0 - 75 A	
Discharge current	0 - 100 A	
Short circuit protection	electronic, at max. charge current, switch off <1 sec	
Supported battery types	check www.PowerRouter.com for supported Li-ion batteries.	

Environmental	PR50SBI-BS	PR37SBI-BS
Operating temperature range (full power)	-10 °C to +50 °C (derating to prevent overtemperature)	
Storage temperature	-40 °C to +70 °C	
Humidity	maximum 95%, non-condensing	
Regulatory approvals and standards	CE, VDE-AR-N 4105:2011-08, EEG2012	
Safety	EN 60950-1, EN 62109-1-2, EN 60335-2-29, EN 62040-1	
Emission	EN 61000-3-2, EN 61000-3-3, EN 61000-6-3, EN 61000-3-12	
Immunity	EN 61000-6-2, EN 61000-3-11	
Anti-islanding protection	VDE 0126.1.1, G83/1(UK), RD1699/2011(ESP), CEI0-21 (IT) (check www.PowerRouter.com for other country certifications)	
Warranty	five years (optional: extension to ten years)	

General	PR50SBI-BS	PR37SBI-BS
Dimensions (W x H x D)	765 x 502 x 149 mm	
Protection category	indoor use (IP20)	
Weight	21.5 kg	
Topology	galvanically isolated transformer	
Cooling	forced airflow	



All specifications apply at 25°C unless stated otherwise.

EN

the PowerRouter

